



RADIO TEST REPORT

Final draft ETSI EN 300 328 V2.2.1 (2019-04)

For

Applicant : SHENZHEN MARK TRADING CO., LTD.

**Address : 6th Floor, Building A, DongFangYaYuan, Chen Tian Communities,
Xixiang Bao'an District, Shenzhen, China**

Product Name : Wireless Game pad

Model Name : GT-60, GT-*, GP-***, EGC-***(**stand for 0-9) (**stand for 0-9)**

Brand Name : MARVO, XTRIKE ME, @ONE

Report No. MTWN19070321

Date of Issue : Jul.29, 2019

Issued by : Shenzhen Most Technology Service Co., Ltd.

**Address : No.5, 2nd Langshan Road, North District, Hi-tech Industrial Park,
Nanshan, Shenzhen, Guangdong, China**

Tel : 86-755-86026850

Fax : 86-755-26013350



The report may be duplicated completely for legal use with the approval of the applicant. It should not be reproduced except in full, without the written approval of our laboratory. The client should not use it to claim product endorsement by MOST. The test results in the report only apply to the tested sample. The test report shall be invalid without all the signatures of testing engineers, reviewer and approver.

CONTENTS

1. Technical Information	4
1.1 Client Description	4
1.2 EUT Description	4
1.3 Objective	6
1.4 Test Standards and Results	6
2. Details of Test	7
2.1 Identification of the Responsible Testing Laboratory	7
2.2 Identification of the Responsible Testing Location	7
2.3 List of Test Equipments	8
2.4 Environmental Conditions	12
2.5 Measurement Uncertainty (95% confidence levels, k=2)	12
2.6 TEST MODE APPLICABILITY AND TESTED CHANNEL DETAIL	12
3. Transmitter Parameters	16
3.1 RF Output Power	16
3.2 Frequency Hopping Requirements	18
3.3 Occupied Channel Bandwidth	24
3.4 Transmitter unwanted emissions in the out-of-band domain	26
3.5 Transmitter spurious emissions	28
4. Receiver spurious emissions	32
4.1 Limit of Receiver spurious emissions	32
4.2 Measuring Instruments	32
4.3 Test Procedures	32
4.4 Test Setup	33
4.5 Radiated measurement worst test Result:	34
5. RECEIVER BLOCKING	35
5.1 LIMIT OF RECEIVER BLOCKING	35
5.2 TEST PROCEDURE	36
5.3 DEVIATION FROM TEST STANDARD	36
5.4 TEST SETUP CONFIGURATION	36
5.5 TEST RESULTS	37
6. Photographs of the Test SETUP	38

TEST RESULT CERTIFICATION

Applicant Name:	SHENZHEN MARK TRADING CO., LTD.
Address:	6th Floor, Building A, DongFangYaYuan, Chen Tian Communities, Xixiang Bao'an District, Shenzhen, China
Manufacturer Name:	SHENZHEN MARK TRADING CO., LTD.
Address:	6th Floor, Building A, DongFangYaYuan, Chen Tian Communities, Xixiang Bao'an District, Shenzhen, China
Brand Name:	MARVO, XTRIKE ME, @ONE
Equipment Under Test:	Wireless Game pad
Model Number:	GT-60
Series Model Number:	GT-***, GP-***, EGC-***(**stand for 0-9) (**stand for 0-9)
Difference description:	Only difference in model names
Test Standard	Final draft ETSI EN 300 328 V2.2.1 (2019-04)
File Number:	MTWN19070321
Date of Test:	Jul.24-26, 2019

We (MOST), for compliance with the requirements set forth in the European Standard ETSI EN 300 328 The results of testing in this report apply to the product/system which was tested only. Other similar equipment will not necessarily produce the same results due to production tolerance and measurement uncertainties.

Tested by (+ signature):

Lili Lu

Lili Lu (Engineer)

Jul.24-26, 2019

Review by (+ signature):

Sunny

Sunny Deng(Engineer)

Jul.29, 2019



Approved by (+ signature):

Yvette

Yvette Zhou(Manager)

Jul.29, 2019

1. Technical Information

Note: the following data is based on the information by the applicant.

1.1 Client Description

Applicant Company	SHENZHEN MARK TRADING CO., LTD.
Applicant Address	6th Floor, Building A, DongFangYaYuan, Chen Tian Communities, Xixiang Bao'an District, Shenzhen, China
Manufacturer Company	SHENZHEN MARK TRADING CO., LTD.
Manufacturer Address	6th Floor, Building A, DongFangYaYuan, Chen Tian Communities, Xixiang Bao'an District, Shenzhen, China

1.2 EUT Description

Product	Wireless Game pad
Brand Name	MARVO
Model Number	GT-60
Frequency Range	2402-2480MHz
Modulation Technique:	FHSS
Modulation Type:	GFSK, $\pi/4$ -DQPSK, 8-DPSK
Number of Channels:	79
Hopping Channel Type:	Adaptive Frequency Hopping systems
EIRP:	0.82dBm (Measured Max.)
Antenna Type	Internal PCB Antenna, 0 dBi Gain.
Power Supply:	DC 5V by USB Port DC 3.7V by Battery
Extreme Temperture:	-20°C ~ +70° C

Note:

1. For more details, please refer to the User's manual of the EUT.
2. The EUT can powered by the Adapter as listed below:

Adapter	
Brand Name	N/A
Model Number	N/A
Input	N/A
Output	N/A

79 channels are provided to BT (GFSK, $\pi/4$ DQPSK, 8 DPSK)

CHANNEL	FREQ. (MHz)	CHANNEL	FREQ. (MHz)	CHANNEL	FREQ. (MHz)	CHANNEL	FREQ. (MHz)
0	2402	20	2422	40	2442	60	2462
1	2403	21	2423	41	2443	61	2463
2	2404	22	2424	42	2444	62	2464
3	2405	23	2425	43	2445	63	2465
4	2406	24	2426	44	2446	64	2466
5	2407	25	2427	45	2447	65	2467
6	2408	26	2428	46	2448	66	2468
7	2409	27	2429	47	2449	67	2469
8	2410	28	2430	48	2450	68	2470
9	2411	29	2431	49	2451	69	2471
10	2412	30	2432	50	2452	70	2472
11	2413	31	2433	51	2453	71	2473
12	2414	32	2434	52	2454	72	2474
13	2415	33	2435	53	2455	73	2475
14	2416	34	2436	54	2456	74	2476
15	2417	35	2437	55	2457	75	2477
16	2418	36	2438	56	2458	76	2478
17	2419	37	2439	57	2459	77	2479
18	2420	38	2440	58	2460	78	2480
19	2421	39	2441	59	2461		

1.3 Objective

Perform Radio Spectrum tests for CE Marking according to the provisions of article 3.2 of the RED Directive (2014/53/EU) for the Bluetooth function of the EUT.

1.4 Test Standards and Results

The EUT has been tested according to Final draft ETSI EN 300 328 V2.2.1 (2019-04)

Final draft ETSI EN 300 328 V2.2.1 (2019-04)	Wideband transmission systems; Data transmission equipment operating in the 2,4 GHz band; Harmonised Standard for access to radio spectrum
--	--

Test items and the results are as bellow:

No.	Basic Standard	Test Item	Result
1	ETSI EN 300 328 4.3.1.2	RF Output Power	Pass
2	ETSI EN 300 328 4.3.1.3	Duty Cycle, Tx-sequence, Tx-gap	Not Applicable
3	ETSI EN 300 328 4.3.1.4	Dwell time, Minimum Frequency Occupation and Hopping Sequence	Pass
4	ETSI EN 300 328 4.3.1.5	Hopping Frequency Separation	Pass
5	ETSI EN 300 328 4.3.1.6	Medium Utilisation (MU) Factor	Not Applicable
6	ETSI EN 300 328 4.3.1.7	Adaptivity (Adaptive Frequency Hopping)	Not Applicable
7	ETSI EN 300 328 4.3.1.8	Occupied Channel Bandwidth	Pass
8	ETSI EN 300 328 4.3.1.9	Transmitter Unwanted Emissions in the Out-of-band Domain	Pass
9	ETSI EN 300 328 4.3.1.10	Transmitter Unwanted Emissions in the Spurious Domain	Pass
10	ETSI EN 300 328 4.3.1.13	Geo-location capability	Not Applicable
11	ETSI EN 300 328 4.3.1.11	Receiver Spurious Emissions	Pass
12	ETSI EN 300 328 4.3.1.12	Receiver Blocking	Pass

2. Details of Test

2.1 Identification of the Responsible Testing Laboratory

Company Name:	Shenzhen Most Technology Service Co., Ltd.
Address:	No.5, 2nd Langshan Road, North District, Hi-tech Industrial Park, Nanshan, Shenzhen, Guangdong, China
Company Name:	Shenzhen Certification Technology Service Co., Ltd.
Address:	Building B, East Area of Nanchang Second Industrial Zone, Gushu 2nd Road, Bao'an District, Shenzhen 518126, P.R. China

2.2 Identification of the Responsible Testing Location

Test Site:	Shenzhen Most Technology Service Co., Ltd.
Address:	No.5, 2nd Langshan Road, North District, Hi-tech Industrial Park, Nanshan, Shenzhen, Guangdong, China
Description:	There is one 3m semi-anechoic an area test sites and two line conducted labs for final test. The Open Area Test Sites and the Line Conducted labs are constructed and calibrated to meet the FCC requirements in documents ANSI C63.4 and CISPR 16 requirements. The CNAS Registration Number is CNAS L3573 .

2.3 List of Test Equipments

No.	Equipment	Manufacturer	Model No.	S/N	Last Cal Date	Cal. Interval
1	Test Receiver	Rohde & Schwarz	ESCI	100492	2019/03/09	1 Year
2	RF Cable	SchwarzBeck	N/A	No.1	2019/03/09	1 Year
3	Bilog Antenna	Sunol	JB3	A121206	2019/03/09	1 Year
4	Horn Antenna	SCHWARZBECK	BBHA9120D	D69250	2019/03/09	1 Year
5	Cable	Resenberger	N/A	NO.2	2019/03/09	1 Year
6	DC Power Filter	DuoJi	DL2×30B	N/A	2019/03/09	1 Year
7	Single Phase Power Line Filter	DuoJi	FNF 202B30	N/A	2019/03/09	1 Year
8	Signal Analyzer	Agilent	N9010A	MY48030494	2019/03/09	1 Year
9	vector Signal Generator	Agilent	E4438C	MY49070163	2019/03/09	1 Year
10	splitter	Mini-Circuits	ZAP-50W	NN256400424	2019/03/09	1 Year
11	Directional Coupler	Agilent	87300C	MY44300299	2019/03/09	1 Year
12	vector Signal Generator	Agilent	E4438C	US44271917	2019/03/09	1 Year
13	Horn Antenna (15GHz-40GHz)	SCHWARZBECK	BBHA 9170	BBHA9170147	2019/03/09	1 Year
14	Signal and Spectrum Analyzer	Rohde&Schwarz	FSV7	102331	2019/03/09	1 Year
15	X-series USB Peak and Average Power Sensor	Agilent	U2021XA	MY53480008	2019/03/09	1 Year
16	X-series USB Peak and Average Power Sensor	Agilent	U2021XA	MY54080019	2019/03/09	1 Year
17	4 Ch.Simultaneous Sampling 14 Bits 2 MS/s	Agilent	U2531A	TW54063507	2019/03/09	1 Year
18	4 Ch.Simultaneous Sampling 14 Bits 2 MS/s	Agilent	U2531A	TW54063513	2019/03/09	1 Year
19	Humid & Temp Programmable Tester	Haida	HD-2257	110807201	2019/03/09	1 Year
20	Oscilloscope	Agilent	DSO9254A	MY51260160	2019/03/09	1 Year
21	splitter	Mini	PS3-7	4463	2019/03/09	1 Year
22	BLUETOOTH TESTER	Rohde&Schwarz	CBT32	100811	2019/03/09	1 Year
23	Amplifier (9kHz-1GHz)	SONOMA	310D	186955	2019/03/09	1 Year

a) The type of modulation used by the equipment:

- FHSS
- other forms of modulation

b) In case of FHSS modulation:

- In case of non-Adaptive Frequency Hopping equipment:
The number of Hopping Frequencies:
- In case of Adaptive Frequency Hopping Equipment:
The maximum number of Hopping Frequencies: 79CH
The minimum number of Hopping Frequencies: 15CH
The Dwell Time: 359.696ms
The Minimum Channel Occupation Time: 0.456ms

c) Adaptive / non-adaptive equipment:

- non-adaptive Equipment
- adaptive Equipment without the possibility to switch to a non-adaptive mode
- adaptive Equipment which can also operate in a non-adaptive mode

d) In case of adaptive equipment:

- The Channel Occupancy Time implemented by the equipment:
- The equipment has implemented an LBT based DAA mechanism
 - In case of equipment using modulation different from FHSS:
 - The equipment is Frame Based equipment
 - The equipment is Load Based equipment
 - The equipment can switch dynamically between Frame Based and Load Based equipment
 - The CCA time implemented by the equipment: μ s
 - The value q as referred to in clause 4.3.2.5.2.2.2
 - The equipment has implemented an non-LBT based DAA mechanism
 - The equipment can operate in more than one adaptive mode

e) In case of non-adaptive Equipment:

- The maximum RF Output Power (e.i.r.p.): 0.82 dBm
 The maximum (corresponding) Duty Cycle: %
 Equipment with dynamic behaviour, that behaviour is described here. (e.g. the different combinations of duty cycle and corresponding power levels to be declared):

f) The worst case operational mode for each of the following tests:

- RF Output Power
FHSS
- Power Spectral Density
FHSS
- Duty cycle, Tx-Sequence, Tx-gap
FHSS
- Dwell time, Minimum Frequency Occupation & Hopping Sequence (only for FHSS equipment)
FHSS
- Hopping Frequency Separation (only for FHSS equipment)
FHSS
- Medium Utilisation
-
- Adaptivity & Receiver Blocking
-
- Occupied Channel Bandwidth
FHSS

- Transmitter unwanted emissions in the OOB domain
FHSS
- Transmitter unwanted emissions in the spurious domain
FHSS
- Receiver spurious emissions
FHSS

g) The different transmit operating modes (tick all that apply):

- Operating mode 1: Single Antenna Equipment
- Equipment with only 1 antenna
- Equipment with 2 diversity antennas but only 1 antenna active at any moment in time
- Smart Antenna Systems with 2 or more antennas, but operating in a (legacy) mode where only 1 antenna is used. (e.g. IEEE 802.11™ [i.3] legacy mode in smart antenna systems)
- Operating mode 2: Smart Antenna Systems - Multiple Antennas without beam forming
- Single spatial stream / Standard throughput / (e.g. IEEE 802.11™ [i.3] legacy mode)
- High Throughput (> 1 spatial stream) using Occupied Channel Bandwidth 1
- High Throughput (> 1 spatial stream) using Occupied Channel Bandwidth 2
- NOTE: Add more lines if more channel bandwidths are supported.
- Operating mode 3: Smart Antenna Systems - Multiple Antennas with beam forming
- Single spatial stream / Standard throughput (e.g. IEEE 802.11™ [i.3] legacy mode)
- High Throughput (> 1 spatial stream) using Occupied Channel Bandwidth 1
- High Throughput (> 1 spatial stream) using Occupied Channel Bandwidth 2
- NOTE: Add more lines if more channel bandwidths are supported.

h) In case of Smart Antenna Systems:

- The number of Receive chains:
- The number of Transmit chains:
- symmetrical power distribution
- asymmetrical power distribution
- In case of beam forming, the maximum beam forming gain:
- NOTE: Beam forming gain does not include the basic gain of a single antenna.

i) Operating Frequency Range(s) of the equipment:

- Operating Frequency Range : 2402 MHz to 2480MHz
- NOTE: Add more lines if more Frequency Ranges are supported.

j) Occupied Channel Bandwidth(s):

- Occupied Channel Bandwidth : 1.1326MHz
- NOTE: Add more lines if more channel bandwidths are supported.

k) Type of Equipment (stand-alone, combined, plug-in radio device, etc.):

- Stand-alone
- Combined Equipment (Equipment where the radio part is fully integrated within another type of equipment)
- Plug-in radio device (Equipment intended for a variety of host systems)
- Other.....

l) The extreme operating conditions that apply to the equipment:

- Operating temperature range: -20°C to 55°C
- Operating voltage range: DC 5V by USB Port or DC 3.7V by Battery
- Details provided are for the: stand-alone equipment
- combined (or host) equipment
- test jig
-

m) The intended combination(s) of the radio equipment power settings and one or more antenna assemblies and their corresponding e.i.r.p levels:

• Antenna Type

Internal PCB Antenna

Antenna Gain: 0 dBi

If applicable, additional beamforming gain (excluding basic antenna gain): dB

Temporary RF connector provided

No temporary RF connector provided

Dedicated Antennas (equipment with antenna connector)

Single power level with corresponding antenna(s)

Multiple power settings and corresponding antenna(s)

Number of different Power Levels:

Power Level 1: dBm

Power Level 2: dBm

Power Level 3: dBm

NOTE 1: Add more lines in case the equipment has more power levels.

NOTE 2: These power levels are conducted power levels (at antenna connector).

n) The nominal voltages of the stand-alone radio equipment or the nominal voltages of the combined (host) equipment or test jig in case of plug-in devices:

Details provided are for the: stand-alone equipment

combined (or host) equipment

test jig Supply Voltage

AC mains State AC voltage :

DC State DC voltage : 5V

In case of DC, indicate the type of power source

Internal Power Supply

External Power Supply or AC/DC adapter

Battery: 3.7V

Other:

o) Describe the test modes available which can facilitate testing:

The EUT can transmit with test software which named RF TestTool

p) The equipment type (e.g. Bluetooth®, IEEE 802.11™ [i.3], proprietary, etc.):

Bluetooth

2.4 Environmental Conditions

During the measurement the environmental conditions were within the listed ranges:

- Temperature: 15-35°C
- Humidity: 30-60 %
- Atmospheric pressure: 86-106 k Pa

2.5 Measurement Uncertainty (95% confidence levels, k=2)

Parameter	Uncertainty
Duty cycle	0.38%
Total RF power, conducted	0.76dB
RF power density, conducted	2.80dB
Spurious emissions, conducted	0.76dB
Radiated Spurious emission test	3.25dB
Temperature test	1°C
Humidity test	3%
DC and low frequency voltages	3%

2.6 TEST MODE APPLICABILITY AND TESTED CHANNEL DETAIL

EUT Configuration Mode	Applicable to											Description
	ROP	DC/TS/TG	ATT/FO/HS	HFS	MU	AD	OCB	EOB	SE< 1G	SE≥ 1G	RB	
-	√	-	√	√	-	-	√	√	√	√	√	DC 5V by USB Port +BT link

Where ROP: RF Output Power

DC/TS/TG: Duty Cycle/ Tx-Sequence / Tx-gap

ATT/MFO/HS: Accumulated Transmit Time /
Frequency Occupation/ Hopping Sequence

HFS: Hopping Frequency Separation

MU: Medium Utilisation

AD: Adaptivity (Channel Access Mechanism)

OCB: Occupied Channel Bandwidth

EOB: Transmitter unwanted emission in the out-of-band domain

SE<1G: Spurious Emissions below

1GHz SE³1G: Spurious Emissions above 1GHz

RB: Receiver Blocking

RF Output Power:

- Pre-Scan has been conducted to determine the worst-case mode from all possible combinations between available modulations, packet type, data rates and antenna ports (if EUT with antenna diversity architecture).

EUT Configure Mode	Available Channel	Tested Channel	Modulation Technology	Modulation Type	Packet Type
-	0 to 78	Hopping mode	FHSS	GFSK	DH5
-	0 to 78	Hopping mode	FHSS	8DPSK	3DH5

Duty Cycle, Tx-sequence, Tx-gap:

- Pre-Scan has been conducted to determine the worst-case mode from all possible combinations between available modulations, packet type, data rates and antenna ports (if EUT with antenna diversity architecture).

EUT Configure Mode	Available Channel	Tested Channel	Modulation Technology	Modulation Type	Packet Type
-	0 to 78	Hopping mode	FHSS	GFSK	DH1, DH3, DH5
-	0 to 78	Hopping mode	FHSS	8DPSK	3DH1, 3DH3, 3DH5

Dwell Time / Minimum Frequency Occupation / Hopping Sequence:

- Pre-Scan has been conducted to determine the worst-case mode from all possible combinations between available modulations, packet type, data rates and antenna ports (if EUT with antenna diversity architecture).

EUT Configure Mode	Available Channel	Tested Channel	Modulation Technology	Modulation Type	Packet Type
-	0 to 78	0, 78	FHSS	GFSK	DH5
-	0 to 78	0, 78	FHSS	8DPSK	3DH5

HOPPING FREQUENCY SEPARATION:

- Pre-Scan has been conducted to determine the worst-case mode from all possible combinations between available modulations, packet type, data rates and antenna ports (if EUT with antenna diversity architecture).

EUT Configure Mode	Available Channel	Tested Channel	Modulation Technology	Modulation Type	Packet Type
-	0 to 78	0, 78	FHSS	GFSK	DH5
-	0 to 78	0, 78	FHSS	8DPSK	3DH5

Occupied Channel Bandwidth:

- Pre-Scan has been conducted to determine the worst-case mode from all possible combinations between available modulations, packet type, data rates and antenna ports (if EUT with antenna diversity architecture).

diversity architecture).

Following channel(s) was (were) selected for the final test as listed below.

EUT configure mode	Available Channel	Tested Channel	Modulation Technology	Modulation Type	Packet Type
-	0 to 78	0, 78	FHSS	GFSK	DH5
-	0 to 78	0, 78	FHSS	8DPSK	3DH5

Transmitter unwanted emission in the out-of-band domain:

Pre-Scan has been conducted to determine the worst-case mode from all possible combinations between available modulations, packet type, data rates and antenna ports (if EUT with antenna diversity architecture)

Following channel(s) was (were) selected for the final test as listed below .

EUT configure mode	Available Channel	Tested Channel	Modulation Technology	Modulation Type	Packet Type
-	0 to 78	Hopping mode	FHSS	GFSK	DH5
-	0 to 78	Hopping mode	FHSS	8DPSK	3DH5

Spurious Emissions Test (Below 1 GHz) :

Pre-Scan has been conducted to determine the worst-case mode from all possible combinations between available modulations, packet type, data rates and antenna ports (if EUT with antenna diversity architecture)

Following channel(s) was (were) selected for the final test as listed below.

EUT configure mode	Available Channel	Tested Channel	Modulation Technology	Modulation Type	Packet Type
-	0 to 78	78	FHSS	GFSK	DH5

Spurious Emissions Test (Above 1 GHz) :

Pre-Scan has been conducted to determine the worst-case mode from all possible combinations between available modulations, packet type, data rates and antenna ports (if EUT with antenna diversity architecture).

Following channel(s) was (were) selected for the final test as listed below.

EUT configure mode	Available Channel	Tested Channel	Modulation Technology	Modulation Type	Packet Type
-	0 to 78	0, 78	FHSS	GFSK	DH5
-	0 to 78	0, 78	FHSS	8DPSK	3DH5

Receiver Blocking Test:

- Pre-Scan has been conducted to determine the worst-case mode from all possible combinations between available modulations, data rates and antenna ports (if EUT with antenna diversity architecture)
- Following channel(s) was (were) selected for the final test as listed below.

EUT Configure Mode	Available Channel	Tested Channel	Modulation Technology	Modulation Type	Packet Type
-	0 to 78	Hopping mode	FHSS	GFSK	DH1

3. Transmitter Parameters

3.1 RF Output Power

3.1.1 Limit of Effective Isotropic Radiated Power

SUBCLAUSE 4.3.1.2.3	
Test Condition	Limit
Normal and Extreme Temperature Conditions	20dBm (e.i.r.p)

3.1.2 Measuring Instruments

The measuring equipment is listed in the section 2.3 of this test report.

3.1.3 Test Procedure

1. The measurement procedure follows the clause 5.4.2.2 of the Final draft ETSI EN 300 328 V2.2.1 (2019-04).
2. Placing the EUT in thermal chamber.
3. The EUT is connected to external power supply.
4. Setting thermal chamber temperature and power supply voltage at suitable values.
5. The EIRP = A+G+Y, where A is the power measured, G is the assembly gain of the individual antenna of the EUT in dBi and Y is the additional beamforming gain of the EUT in dB if applicable, here, Y=0
6. Use a fast power sensor suitable for 2.4 GHz and capable of 1 MS/s.
7. Use the following settings:
 - Sample speed 1 MS/s or faster.
 - The samples must represent the power of the signal.
 - Measurement duration: For non-adaptive equipment: equal to the observation period defined in clauses 4.3.1.3.2 or 4.3.2.4.2. For adaptive equipment, the measurement duration shall be long enough to ensure a minimum number of bursts (at least 10) are captured.

3.1.4 Test Setup

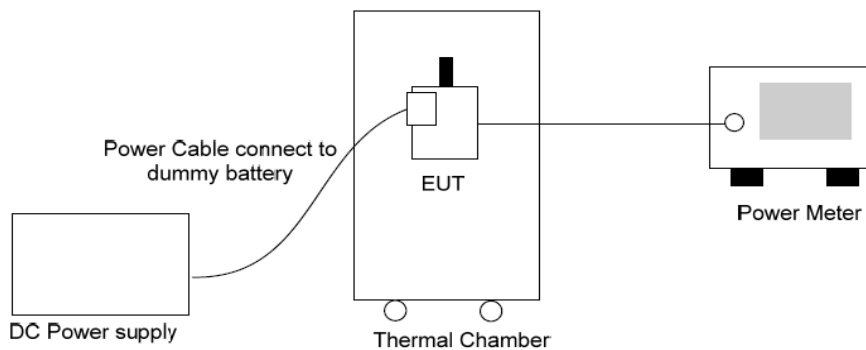

3.1.5 Test Result

Test Item:	EIRP Power	Temperature :	24°C
Test Engineer:	Joe	Relative Humidity :	96k Pa

Test Conditions		Mode	Gain (dBi)	EIRP (dBm)	Limit (dBm)	Pass/Fail
Temp (°C)	Volt (V DC)					
Normal (25.0)	Normal	GFSK	0	0.82	20	Pass
		π /4DQPSK		0.56	20	Pass
		8DPSK		0.74	20	Pass
-20		GFSK		0.73	20	Pass
		π /4DQPSK		0.61	20	Pass
		8DPSK		0.58	20	Pass
55		GFSK		0.46	20	Pass
		π /4DQPSK		0.55	20	Pass
		8DPSK		0.67	20	Pass

Remark:

EIRP= read level(dBm) +cable loss+ Product antenna gain

3.2 Frequency Hopping Requirements

3.2.1 Dwell Time and Minimum Frequency Occupation Time

3.2.1.1 Limit of Dwell Time

SUBCLAUSE 4.3.1.4.3	
Test Condition	Limit
Non-Adaptive Frequency Hopping Systems	15 ms within 15ms * hopping frequencies (N)
Adaptive Frequency Hopping Systems	0.4s within 0.4s * hopping frequencies (N)

Limit of Minimum Frequency Occupation Time

SUBCLAUSE 4.3.1.4.3	
Test Condition	Limit
Normal Conditions	The Minimum Frequency Occupation Time shall be equal to one dwell time within a period not exceeding four times the product of the dwell time per hop and the number of hopping frequencies in use.

Remark: This test item is not applicable to DSSS/OFDM device.

3.2.1.2 Measuring Instruments

The measuring equipment is listed in the section 2.3 of this test report.

3.2.1.3 Test Procedure

1. The measurement shall be performed on a minimum of 2 hopping frequencies chosen arbitrary from the actual hopping sequence. The results as well as the frequencies on which the test was performed shall be recorded in the test report.
2. The measurement procedure follows the clause 5.4.4.2.1 of the Final draft ETSI EN 300 328 V2.2.1 (2019-04).
3. The analyzer shall be set as follows:

Center Frequency	Channel under test
Frequency Span	0 Hz
Resolution BW	300kHz
Video BW	300kHz
Detector	RMS
Sweep time	Equal to the Dwell Time x Minimum number of hopping frequencies (N)
Number of sweep points	30000
Trace Mode	Clear/Write
Trigger	Free Run

4. For accuracy measurement, the sweep time would be zoomed in and verify the dwell time which is from the dwell time per hop across the total number of hopping channel. Then record test result in the section 3.4.1.5.
5. Make the following changes on the analyzer to get Minimum Frequency Occupation Time Sweep time: Equal to 4 x Dwell Time x Actual number of hopping frequencies in use

3.2.1.4 Test Setup



1.1.1.1 Test Result

Test Item:	Dwell time	Temperature :	25°C
Test Engineer:	Joe	Relative Humidity :	96k Pa

BT (Hopping Mode)	Number of transmission in a period (channel number*0.4 sec)				Length of transmission time (ms)	Result (ms)	Limit (ms)	Pass /Fail	
	Period (Sec)	Sweep time (Sec)	Times in a sweep	Times in a period					
GFSK	DH1	31.6	5	41	259.12	0.456	118.159	400	Pass
	DH3	31.6	5	27	170.64	1.512	258.008	400	Pass
	DH5	31.6	5	26	164.32	2.189	359.696	400	Pass
8DPSK	3DH1	31.6	5	46	290.72	0.536	155.826	400	Pass
	3DH3	31.6	5	28	176.96	1.412	249.868	400	Pass
	3DH5	31.6	5	26	164.32	2.087	342.936	400	Pass

Remark:

1. Maximum accumulated dwell time = no. of hop within the testing period x dell time per hop

2. The test period: T= 400ms x 79 Channel = 31.6 s (for accumulated dwell time)

NOTE: Test plots of the transmitting time slot are shown as below.

Test Item:	Dwell time	Temperature :	25°C
Test Engineer:	Joe	Relative Humidity :	96k Pa

MINIMUM FREQUENCY OCCUPATION TIME						
BT (Hopping Mode)		Number of transmission in a period of 4*Dwell time*number of hopping channel	Length of transmission time (ms)	Result (ms)	Minimum Limit (ms)	Pass /Fail
GFSK	DH1	2	0.456	0.912	0.456	Pass
	DH3	3	1.512	4.536	1.512	Pass
	DH5	4	2.189	8.756	2.189	Pass
8DPSK	3DH1	2	0.536	1.072	0.536	Pass
	3DH3	3	1.412	4.236	1.412	Pass
	3DH5	4	2.087	8.348	2.087	Pass
Remark: NOTE: Test plots of the transmitting time slot are shown as below.						

3.2.1.5 Hopping Sequence

3.2.1.6 Limit of Hopping Sequence

SUBCLAUSE 4.3.1.4.3	
Test Condition	Limit
Non-Adaptive Frequency Hopping Systems	N
Adaptive Frequency Hopping Systems	N Ch 70% of band

N= 15 or 15 divided by the minimum Hopping Frequency Separation in MHz' whichever is the greater.
Remark: Hopping Sequence is not applicable to DSSS/OFDM device.

3.2.1.7 Measuring Instruments

The measuring equipment is listed in the section 2.3 of this test report.

3.2.1.8 Test Procedure

The measurement procedure follows the clause 5.4.4.2.1 of the Final draft ETSI EN 300 328 V2.2.1 (2019-04).

3.2.1.9 Test Setup



3.2.1.10 Test Result

Test Item:	Hopping Sequence	Temperature :	23°C
Test Engineer:	Joe	Relative Humidity :	96k Pa

Mode	Operation band (20dB down)(MHz)	Occupied band (%)	Limit (%)	Hopping sequence	Limit
GFSK	79.91	95.70	70	79	15
8DPSK	79.85	95.63	70	79	15

3.2.2 Hopping Frequency Separation

3.2.3 Limit of Hopping Frequency Separation

SUBCLAUSE 4.3.1.5.3	
Test Condition	Limit
Non-Adaptive Frequency Hopping Systems	MAX [OBW, 100kHz]
Adaptive Frequency Hopping Systems	100kHz

Remark: Hopping Frequency Separation is not applicable to DSSS/OFDM device.

3.2.4 Measuring Instruments

The measuring equipment is listed in the section 3.3 of this test report.

3.2.5 Test Procedure

1. These measurements shall only be performed at normal test conditions.
2. The measurement shall be performed on 2 adjacent hopping frequencies.
3. The frequencies on which the test was performed shall be recorded.
4. The measurement procedure follows the clause 5.4.5.2.1.2 Option 2 of the Final draft ETSI EN 300 328 V2.2.1 (2019-04).

3.2.6 Test Setup



3.2.7 Test Result

Test Item:	Frequency Separation	Temperature :	24°C
Test Engineer:	Joe	Relative Humidity :	96k Pa

Mode	Frequency(MHz)	Separation(MHz)	Limit(MHz)	Pass /Fail
GFSK	2402	1.014	>0.1	Pass
	2480	1.014	>0.1	Pass
8DPSK	2402	1.015	>0.1	Pass
	2480	1.015	>0.1	Pass

Note: The limitation is from OCB of a single hop and this value must greater and equal to 100 kHz.

3.3 Occupied Channel Bandwidth

3.3.1 Limit of Occupied Channel Bandwidth

SUBCLAUSE 4.3.1.8.3 and 4.3.2.7.3		
Test Condition	Limit	
All types of equipment	Shall fall completely within the band 2400 to 2483.5 MHz.	
Additional requirement	For non-adaptive using wide band modulations other than FHSS system and e.i.r.p >10dBm.	Less than 20MHz
	For non-adaptive Frequency Hopping system and e.i.r.p >10dBm.	Less than 5MHz

3.3.2 Measuring Instruments

The measuring equipment is listed in the section 2.3 of this test report.

3.3.3 Test Procedure

1. The measurement procedure follows the clause 5.4.7.2.1 of the Final draft ETSI EN 300 328 V2.2.1 (2019-04).
2. The measurement shall be performed only on the lowest and the highest frequency within the stated frequency range.
3. The analyzer shall be set as follows:

Step 1:

Connect the EUT to the spectrum analyzer and use the following settings:

Center Frequency	Channel under test
Resolution BW	1 % of the span
Video BW	3xRBW
Frequency Span	2 x Occupied Channel Bandwidth (e.g. 40 MHz for a 20 MHz channel)
Detector	RMS
Trace Mode	Max Hold

Step 2:

Wait until the trace is completed.

Find the peak value of the trace and place the analyzer marker on this peak.

Step 3:

Use the 99 % bandwidth function of the spectrum analyzer to measure the Occupied Channel Bandwidth of the EUT.

3.3.4 Test Setup



3.3.5 Test Result

Test Item:	99% Occupied BW	Temperature :	24°C
Test Engineer:	Joe	Relative Humidity :	96k Pa

Mode.	Channel	Freq (MHz)	99% Occupied Bandwidth (MHz)	FL (MHz)	FH (MHz)	Limit (MHz)	Pass /Fail
GFSK	0	2402	0.9641	2401.5218	2402.4859	FL>2400 and FH<2483.5	Pass
	78	2480	0.9539	2479.5948	2480.5487		Pass
8-DPSK	0	2402	1.1215	2401.4627	2402.5842	FL>2400 and FH<2483.5	Pass
	78	2480	1.1326	2479.4586	2480.5912		Pass

3.4 Transmitter unwanted emissions in the out-of-band domain

3.4.1 Transmitter unwanted emissions in the out-of-band domain Limit

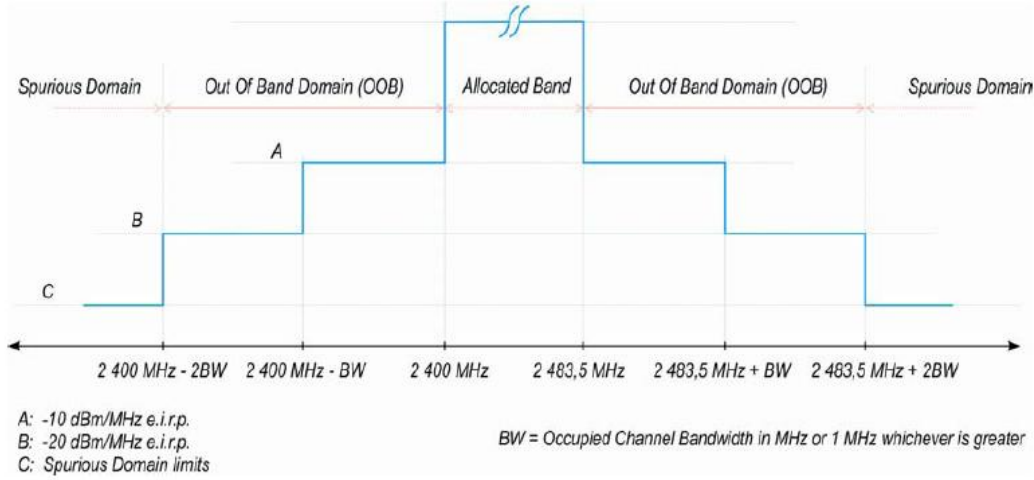

3.4.2 Measuring Instruments

The measuring equipment is listed in the section 2.3 of this test report.

3.4.3 Test Procedure

1. The measurement procedure follows the clause 5.4.8.2.1 of the Final draft ETSI EN 300 328 V2.2.1 (2019-04).
2. These measurements shall be performed at both normal environmental conditions and at the extremes of the operating temperature range..
3. For conducted measurements on devices with multiple transmit chains using the results for each of the transmit chains for the corresponding 1 MHz segments shall be added and compared with the transmit mask limit.

3.4.4 Test Setup



3.4.5 Test Result

Test Item:	OOB emissions	Temperature :	24°C
Test Engineer:	Joe	Relative Humidity :	96k Pa

Test Conditions		Mode	Test Segment (MHz)	Max. Reading (dBm/MHz)	Limit (dBm /MHz)	Pass /Fail
Temp (°C)	Volt (V DC)					
Normal (25.0)	Normal	GFSK	2400-2BW to 2400-BW	-60.47	-20	Pass
			2400-BW to 2400	-56.61	-10	Pass
			2483.5 to 2483.5+BW	-59.78	-10	Pass
			2483.5+BW to 2483.5+2BW	-61.34	-20	Pass
		8DPSK	2400-2BW to 2400-BW	-67.39	-20	Pass
			2400-BW to 2400	-55.58	-10	Pass
			2483.5 to 2483.5+BW	-61.29	-10	Pass
			2483.5+BW to 2483.5+2BW	-61.43	-20	Pass

3.5 Transmitter spurious emissions

3.5.1 Limit of Transmitter spurious emissions

Spurious emission limits for transmitter:

SUBCLAUSE 4.3.1.10.3 and 4.3.2.9.3		
FREQUENCY RANGE	MAXIMUM POWER E.R.P. 1 GHZ) E.I.R.P. (> 1 GHZ)	BANDWIDTH
30 MHz to 47 MHz	-36 dBm	100 kHz
47 MHz to 74 MHz	-54 dBm	100 kHz
74 MHz to 87,5 MHz	-36 dBm	100 kHz
87,5 MHz to 118 MHz	-54 dBm	100 kHz
118MHzto174MHz	-36 dBm	100 kHz
174 MHz to 230 MHz	-54 dBm	100 kHz
230 MHz to 470 MHz	-36 dBm	100 kHz
470 MHz to 862 MHz	-54 dBm	100 kHz
862 MHz to 1 GHz	-36 dBm	100 kHz
1 GHz to 12,75 GHz	-30 dBm	1 MHz

3.5.2 Measuring Instruments

The measuring equipment is listed in the section 7 of this test report.

3.5.3 Test Procedures

1. The measurement procedure follows the clause 5.4.9.2.1.2 of the Final draft ETSI EN 300 328 V2.2.1 (2019-04).
2. The EUT was placed on a turntable with 1.5m height.
3. The test distance between the receiving antenna and the EUT is 3meter below 1 GHz frequency range, and 3 meter which is in far field test condition for measured frequency above 1GHz, while the receiving (test) antenna is kept at 1.5 meter height.
4. Set EUT in continuous transmitting with maximum output power.
5. The table was rotated from 0 to 360 degree to search the highest radiated emission.
6. Repeating step 3 and 4 for each polarization and channel to find the worst emission level.
7. The results obtained are compared to the limits in order to prove compliance with the requirement.

3.5.4 Test Setup

For radiated measurement:

Below 1GHz

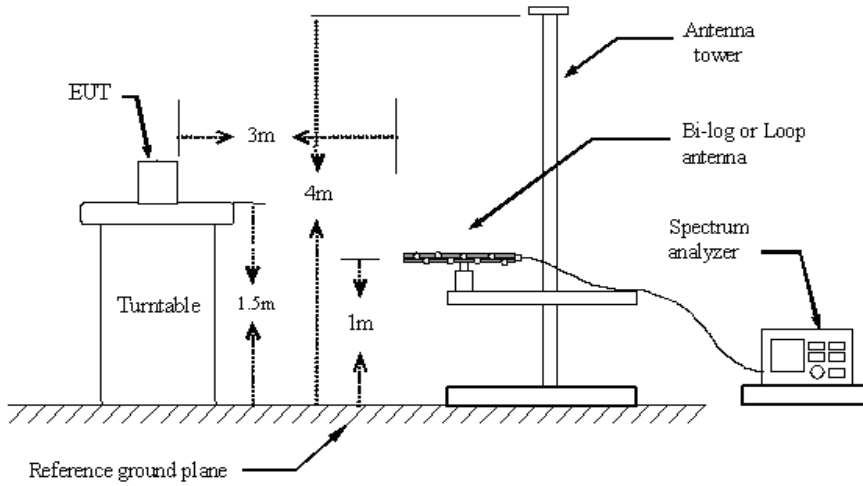

Above 1GHz

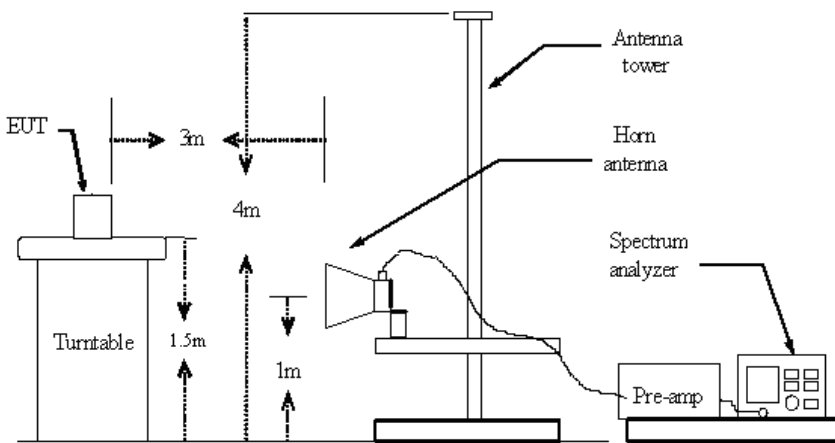

For conducted measurement:

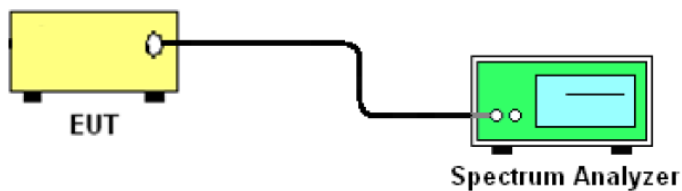

3.5.5 Radiated measurement worst test Result:

Channel	Frequency	Measurement Bandwidth	Level	Limit	Margin
	MHz	KHz	ERP	dBm	dB
Mode: GFSK Vertical					
0	572.36	100	-59.75	-54	-5.75
	4735	1000	-37.38	-30	-7.38
	7145	1000	\	-30	>10
	9537	1000	\	-30	>10
	12104	1000	\	-30	>10
	other	1000	\	-30	>10
Mode: GFSK Vertical					
0	489.56	100	-60.43	-54	-6.43
	4804	1000	-38.52	-30	-8.52
	7213	1000	\	-30	>10
	9628	1000	\	-30	>10
	12312	1000	\	-30	>10
	other	1000	\	-30	>10
Mode: GFSK Horizontal					
78	227.23	100	-62.65	-54	-8.65
	4745	1000	-38.41	-30	-8.41
	7346	1000	\	-30	>10
	9714	1000	\	-30	>10
	12349	1000	\	-30	>10
	other	1000	\	-30	>10
Mode: GFSK Horizontal					
78	215.22	100	-62.51	-54	-8.51
	4741	1000	-38.34	-30	-8.34
	7329	1000	\	-30	>10
	9802	1000	\	-30	>10
	12217	1000	\	-30	>10
	other	1000	\	-30	>10

Note: The test frequency range is 30MHz to 12.75GHz.

Conducted measurement worst test Result:

Channel	Frequency	Measurement Bandwidth	Emissions Level	Limit	Margin
	MHz	KHz	dBm	dBm	dB
Mode: GFSK					
0	351.47	100	-42.58	-36	-6.58
	435.25	100	-49.61	-36	-13.61
	4841	1000	-50.35	-30	-14.35
	other	\	\	\	\
78	371.45	100	-42.46	-36	-6.46
	584.53	100	-44.57	-54	-9.57
	4861.14	1000	-49.28	-30	-13.28
	other	\	\	\	\
Measurement uncertainty: ±3.2dB					

Notes:

" in the table above means that the emissions are too small to be measured and are at least 20 dB below the limit

4. Receiver spurious emissions

4.1 Limit of Receiver spurious emissions

FHSS spurious emission limits for receivers:

SUBCLAUSE 4.3.1.11.3		
FREQUENCY RANGE	MAXIMUM POWER E.R.P. (< 1 GHZ) E.I.R.P. (> 1 GHZ)	MEASUREMENT BANDWIDTH
30 MHz to 1 GHz	-57 dBm	100kHz
1 GHz to 12,75 GHz	-47 dBm	1MHz

4.2 Measuring Instruments

The measuring equipment is listed in the section 7 of this test report.

4.3 Test Procedures

1. The measurement procedure follows the clause 5.4.10.2.1.2 of the Final draft ETSI EN 300 328 V2.2.1 (2019-04).
2. The EUT was placed on a turntable with 1.5m height.
3. The test distance between the receiving antenna and the EUT is 3meter below 1GHz frequency range, and 3 meter which is in far field test condition for measured frequency above 1 GHz, while the receiving (test) antenna is kept at 1.5 meter height.
4. Set EUT in receiving mode.
5. The table was rotated from 0 to 360 degree to search the highest radiated emission.
6. Repeating step 3 and 4 for each polarization and channel to find the worst emission level.
7. The results obtained are compared to the limits in order to prove compliance with the requirement.

4.4 Test Setup

For radiated measurement:

Below 1GHz

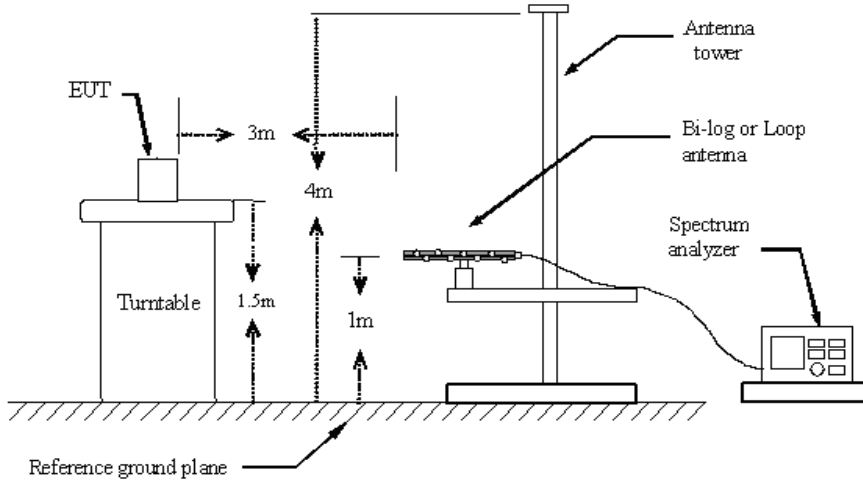

Above 1GHz

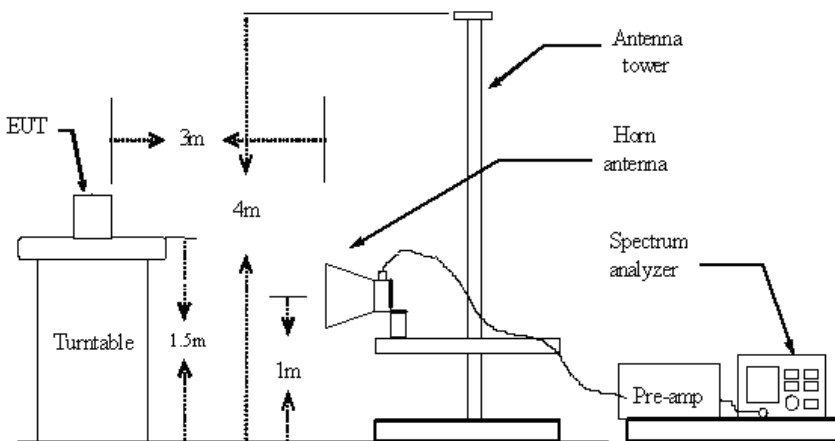

For conducted measurement:

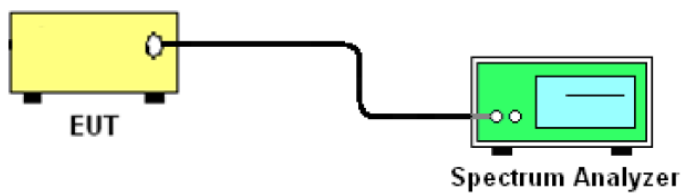

4.5 Radiated measurement worst test Result:

Channel	Frequency	Measurement Bandwidth	Level	Limit	Margin
	MHz	KHz	ERP	dBm	dB
Mode: GFSK Vertical					
0	581.25	100	-63.53	-57	-6.53
	2231.37	1000	-55.47	-47	-8.47
	other	1000	\	-47	
Mode: GFSK Horizontal					
0	572.34	100	-64.34	-57	-7.34
	2218.69	1000	-55.51	-47	-8.51
	other	1000	\	-47	>10
Mode: GFSK Vertical					
78	648.93	100	-64.29	-57	-7.29
	2235.75	1000	-55.32	-47	-8.32
	other	1000	\	-47	>10
Mode: GFSK Horizontal					
78	656.38	100	-64.39	-57	-7.39
	2218.69	1000	-55.28	-47	-8.28
	other	1000	\	-47	>10

Note: The test frequency range is 30MHz to 12.75GHz.

Conducted measurement worst test Result:

Channel	Frequency	Measurement Bandwidth	Emissions Level	Limit	Margin
	MHz	KHz	dBm	dBm	dB
Mode: GFSK					
0	574.39	100	-61.48	-57	-4.48
	851.36	100	-62.29	-57	-5.29
	1453.65	1000	-57.56	-47	-10.56
	other	\	\	\	\
78	415.36	100	-62.35	-57	-5.35
	763.57	100	-63.41	-57	-6.41
	1535.62	1000	-56.53	-47	-9.53
	other	\	\	\	\
Measurement uncertainty: ±3.2dB					

Notes:

"\" in the table above means that the emissions are too small to be measured and are at least 20 dB below the limit

5. RECEIVER BLOCKING

5.1 LIMIT OF RECEIVER BLOCKING

This requirement applies to all receiver categories.

Receiver Category		
Category 1	Category 2	Category 3
Minimum performance criterion	PER $\leq 10\%$	
	Alternative performance criteria (See note)	
Note: The manufacturer was declared performance criteria is x% for the intended use of the equipment.		

Receiver Category 1 Equipment			
Wanted signal mean power from companion device (dBm)	Blocking Signal Frequency (MHz)	Blocking Signal Power (dBm) (See note 2)	Type of blocking signal
$P_{min} + 6$ dB	2 380 2 503.5	-53	CW
$P_{min} + 6$ dB	2 300 2 330 2 360	-47	CW
$P_{min} + 6$ dB	2 523.5 2 553.5 2 583.5 2 613.5 2 643.5 2 673.5	-47	CW
NOTE 1: P_{min} is the minimum level of the wanted signal (in dBm) required to meet the minimum performance criteria as defined in clause 4.3.2.11.3 in the absence of any blocking signal.			
NOTE 2: The levels specified are levels in front of the UUT antenna. In case of conducted measurements, the levels have to be corrected by the actual antenna assembly gain.			

Receiver Category 2 Equipment			
Wanted signal mean power from companion device (dBm)	Blocking Signal Frequency (MHz)	Blocking Signal Power (dBm) (See note 2)	Type of blocking signal
$P_{min} + 6$ dB	2 380 2 503.5	-57	CW
$P_{min} + 6$ dB	2 300 2 583.5	-47	CW
NOTE 1: P_{min} is the minimum level of the wanted signal (in dBm) required to meet the minimum performance criteria as defined in clause 4.3.2.11.3 in the absence of any blocking signal.			
NOTE 2: The levels specified are levels in front of the UUT antenna. In case of conducted measurements, the levels have to be corrected by the actual antenna assembly gain.			

Receiver Category 3 Equipment			
Wanted signal mean power from companion device (dBm)	Blocking Signal Frequency (MHz)	Blocking Signal Power (dBm) (See note 2)	Type of blocking signal
$P_{min} + 12$ dB	2 380 2 503.5	-57	CW
$P_{min} + 12$ dB	2 300 2 583.5	-47	CW

NOTE 1: P_{min} is the minimum level of the wanted signal (in dBm) required to meet the minimum performance criteria as defined in clause 4.3.2.11.3 in the absence of any blocking signal.
NOTE 2: The levels specified are levels in front of the UUT antenna. In case of conducted measurements, the levels have to be corrected by the actual antenna assembly gain.

5.2 TEST PROCEDURE

Refer to chapter 5.4.11 of EN 300 328 V2.2.1.

Measurement	Method
Conducted measurement	Radiated measurement

5.3 DEVIATION FROM TEST STANDARD

No deviation.

5.4 TEST SETUP CONFIGURATION

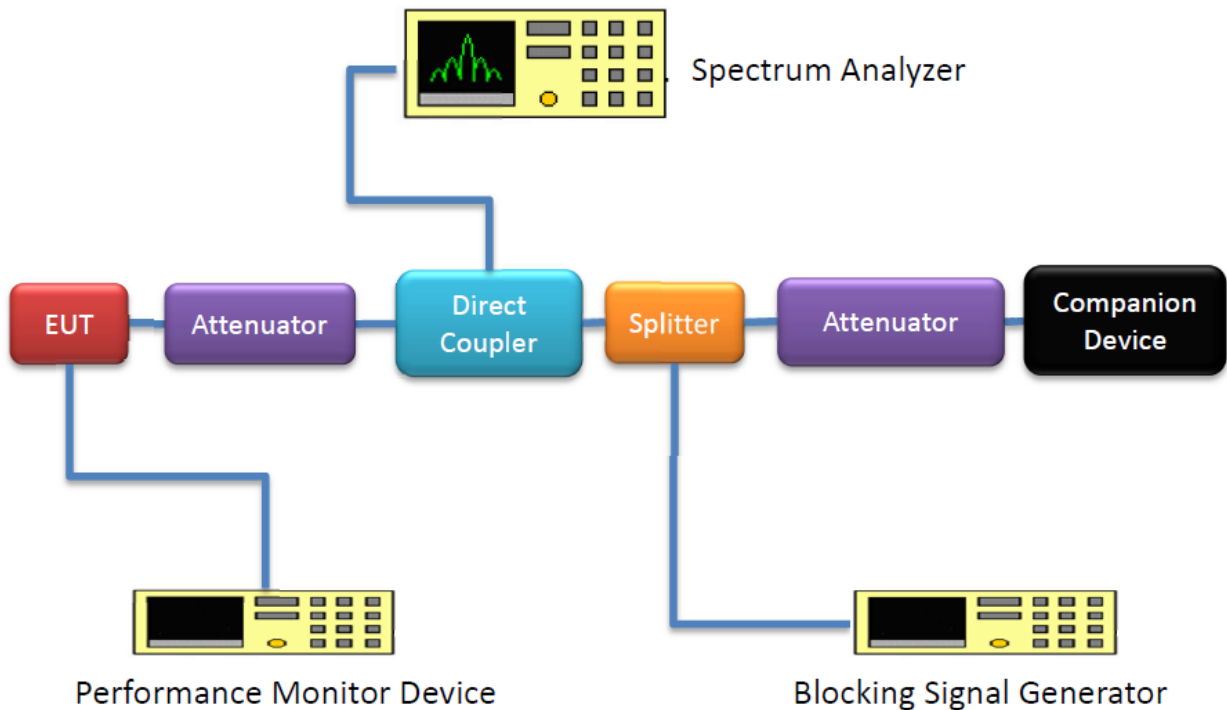

5.5 TEST RESULTS

Receiver Category 2 Equipment

Receiver blocking performance when operating at BT(EDR) mode				
P _{min} : -82.35dBm			antenna gain(G) : 0dBi	
The actual blocking signal power(Note1)			at the antenna connector	
			in front of the antenna	
Note1: For the conducted measurements , the level shall be corrected as follows: the actual blocking signal power = blocking signal power + G				
Wanted signal mean power from companion device (dBm)	Blocking signal frequency (MHz)	The actual blocking signal power (dBm)	PER(%)	Pass/Fail
P _{min} + 6 dB	2380	-57	0.63	PASS
	2503.5	-57	0.45	PASS
	2300	-47	0.53	PASS
	2583.5	-47	0.36	PASS

6. Photographs of the Test SETUP

Radiated Emission Test Setup



*** End of the Reports***